



Viscous Speed Governors (VSG)



VSG leads the expansion of our core product offering

The VSG's simple, lightweight rugged construction provides reliable performance for numerous industrial applications. The VSG controls rotation of shafts and hinged loads by using silicone-based viscous shearing technology. An inner rotor is surrounded by silicone fluid within the stationary housing. As the shaft rotates, the inner rotor shears the silicone fluid providing resistance and smooth motion. Fluid viscosity of each VSG is selected after considering variables such as the components size, weight, spring assist and desired cycle time.

Common Applications

- Overhead and rolling steel fire doors, grilles, and shutters
- Conveying - braking of free conveyor rollers and ramps
- Material Handling - hoist integration, free-fall load protection
- Steering Control - resistance offers over-steering protection
- Amusement Industry - limiting sway and range of motion
- Industrial Safety - controlling shaft or hinged loads
- Marine Applications - 100% high-tech, non metallic construction

Typical VSG Application Lateral Motion

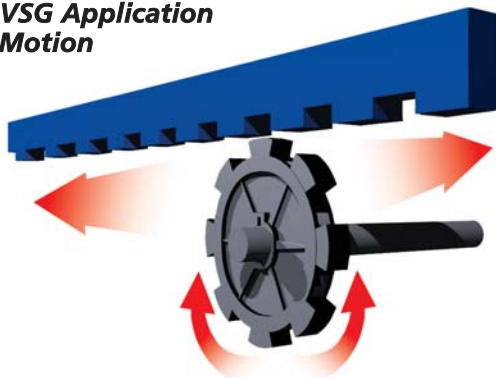

Features and Benefits

- Safely and quietly controls rotary motion
- Provides consistent speed control through 360° of rotation, in both directions
- Handles linear motion via simple rack and pinion integration
- Industry standard shaft and keyway mounting configurations
- Wide range of ambient operating conditions - indoor or outdoor, -40° F to +200° F (-40° C to +95° C)
- Customer-specified performance over a wide range of operating RPM
- Maintenance-free - no adjustments required

Typical Shaft Installation Exploded View

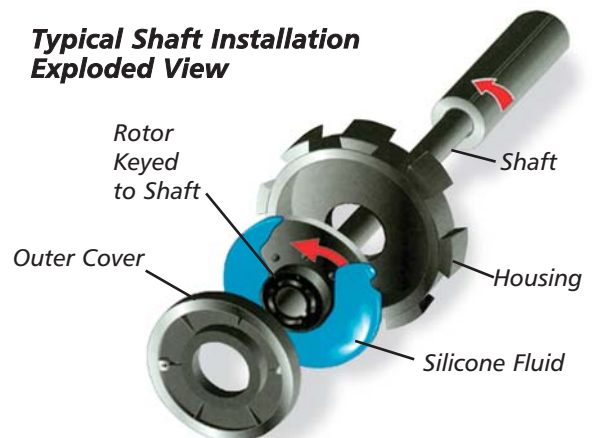

Ideally suited for the Rolling Overhead and Fire Door Control

In new and retrofit applications, a single VSG can be installed on rolling doors by simply mounting to the keyed door shaft per the original door manufacturer's instructions. Unlike noisy ratcheting devices, the VSG requires no adjustments during installation or while in-service and can control the closing and opening speed of most large doors. Multiple governors can be used to handle over-sized doors.

Currently in use by most major door manufacturers, the patented VSG meets industry standards outlined by Underwriters Laboratory, Warnock Hersey and Factory Mutual. It has passed the 3-hour fire door burn test and conforms to numerous industry standards.



ITT

Koni
Enidine

ENIDINE

Specifications



Dimensional Data

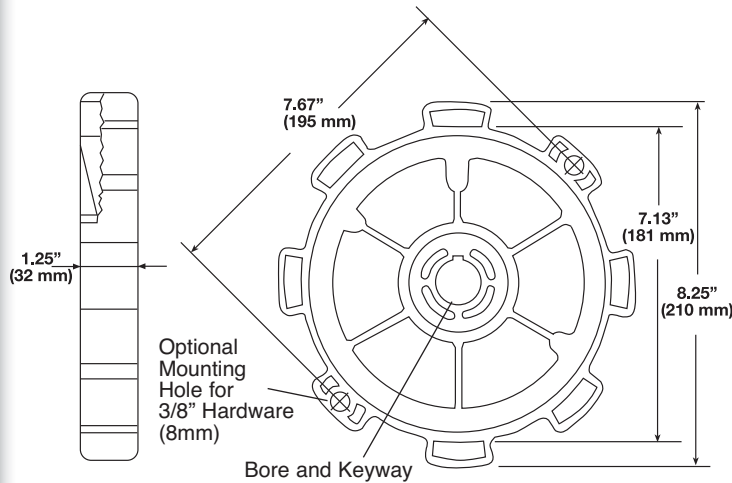

Performance Characteristics

Breakaway Torque Requirements:

35 in-lbs. (4 Nm.) for fluids 1K, 5K, 10K (cSt.)
 50 in-lbs. (5.6 Nm.) for fluids 30K and 60K (cSt.)
 70 in-lbs. (8 Nm.) for fluids 100K+ (cSt.)

Dynamic Torque: Refer to Selection Guides Below.
 (Torque values +/- 10%)

Operating Temperature: -40° F to +200° F
 (-40° C to +95° C)

Listings/Labels:



CLASSIFIED



CLASSIFIED



Warnock Hersey
LISTED

TORQUE BASED SELECTION GUIDE FOR VARIOUS SILICONE VISCOSITIES (cSt.)

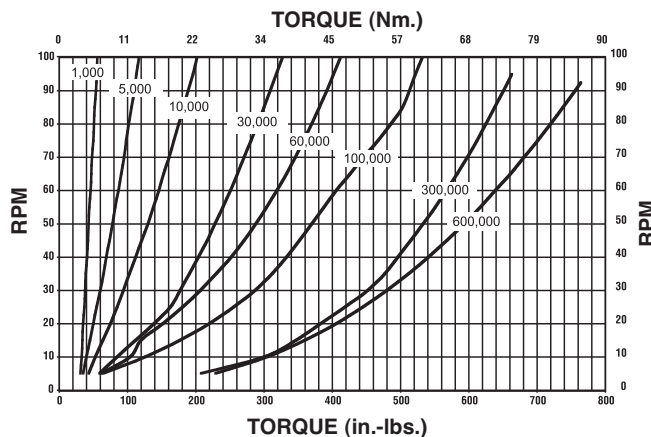

World Headquarters

Enidine Incorporated
 7 Centre Drive
 Orchard Park, New York 14127
 USA
 Phone: 716-662-1900
 Fax: 716-662-1909
 www.enidine.com

Subsidiaries & Affiliates

Enidine Europe
 Hauptstr, 435
 79576 Weil am Rhein
 Germany
 Phone: 49 7621 98679 0
 Fax: 49 7621 98679 82
 www.enidine.eu

Enidine / Jarret SAS
 14-38, rue Alexandre, Bat E2
 BP35
 Gennevilliers, CEDEX, 92234
 France
 Phone: 33 1 41 32 26 60
 Fax: 33 1 40 86 12 82
 www.enidine-europe.com
 www.jarret.fr

Ordering Information

Specify Part Number
 (example: A715477-005)



- | | |
|--------------------------|-----|
| A = 1" x 1/4" | 005 |
| C = 1-1/4" x 1/4" | 010 |
| E = 1-1/4" x 3/8" | 030 |
| F = 1-1/2" x 3/8" | 060 |
| M = Ø32mm x 10mm | 100 |
| | 300 |
| | 600 |

Specify Required
 Shaft-Bore x Keyway

Specify Required
 Fluid Viscosity x '000

Description

- Material:** High Performance Polymer Composite
- Weight:** 2.0 lbs. (1.0 Kg.)
- Damping Medium:** Silicone Fluid available in:
 1K, 5K, 10K, 30K, 60K, 100K, 300K, 600K cSt.
- OEM Application:** Govern Descent of Rolling Steel Fire Doors

QUICK SELECTION GUIDE FOR ROLLING STEEL DOOR WITH SPRING KICK SILICONE VISCOSITY (cSt.)

