



ITT

Heavy Duty Shock Absorbers



Engineered for life

HEAVY DUTY SHOCK ABSORBERS



Applications:

- Amusement ride emergency stops
- Transportation safety stops
- Ladle transfer cars
- Coil upenders/downenders
- Rolling mill chock separators
- Furnace slab bumpers
- Hot strip mill down-coiler
- Re-heat furnace entry end shock absorber
- Gantry/Stacker Cranes



Table of Contents

Product Selection

Company Overview	1
New Technologies and Enhancements	2
Theory of Energy Absorption	3
Sizing Examples	4-6

Energy Absorption Products

HDN/HDA Series (Heavy Duty Shock Absorbers)	
Overview	7
Technical Data	8-14
Adjustment Techniques	13-14
HD Series (Heavy Duty Shock Absorbers)	
Overview	15
Technical Data	16-17
Mounting and Accessories	18-19
Ordering Information	20
Application Worksheet	21

Enidine, a preferred source for energy absorption and vibration isolation solutions, offers a full range of Heavy Duty (HDN/HDA) products, each designed to protect equipment from large impacts in applications where consistent deceleration and safety is required.

Need Assistance? Enidine is ready to answer your questions, feel free to contact us at:

Phone: +49 6063 9314 0

Fax: +49 6063 9314 44

Email: info@enidine.eu

Online: www.enidine.eu





With its world headquarters located in Orchard Park, New York, USA, **ENIDINE Incorporated** is a world leader in the design and manufacture of standard and custom energy absorption and vibration isolation product solutions within the Industrial, Aerospace, Defense, Marine and Rail markets. Product ranges include shock absorbers, gas springs, rate controls, air springs, wire rope isolators, heavy industry buffers and emergency stops. With facilities strategically located throughout the world and in partnership with our vast global network of distributors, Enidine Incorporated continues to strengthen its presence within marketplace.

Founded in 1966, Enidine Incorporated now has close to 600 employees located throughout the globe in the United States, Germany, France, Japan, China and Korea. With a team of professionals in engineering, computer science, manufacturing, production and marketing our employees provide our customers the very best in service and application solutions.

“Enidine is widely recognized as the preferred source for energy absorption and vibration isolation products.”

From Original Equipment Manufacturers (OEM) to aftermarket applications, Enidine offers a unique combination of product selection, engineering excellence and technical support to meet even the toughest energy absorption application requirements.

Global Manufacturing and Sales Facilities offer our customers:

- **Highly Trained Distribution Network**
- **State-of-the Art Engineering Capabilities**
- **Custom Solution Development**
- **Customer Service Specialists**
- **Multiple Open Communication Channels**

If you are unsure whether one of our standard products meets your requirements, feel free to speak with one of our technical representatives **at +49 6063 9314 0**, or contact us via **e-mail at info@enidine.eu**.

Products/Engineering/Technical Support

Enidine continually strives to provide the widest selection of shock absorbers and rate control products in the global marketplace. Through constant evaluation and testing, we bring our customers the most cost effective products with more features, greater performance and improved ease of use.

Enidine engineers continue to monitor and influence trends in the motion control industry, allowing us to remain at the forefront of new energy absorption and vibration isolation product development.

Our experienced engineering team has designed custom solutions for a wide variety of challenging applications, including automated warehousing systems and shock absorbers for hostile industrial environments such as glass manufacturing, among others. These custom application solutions have proven to be critical to our customers' success. Let Enidine engineers do the same for you.

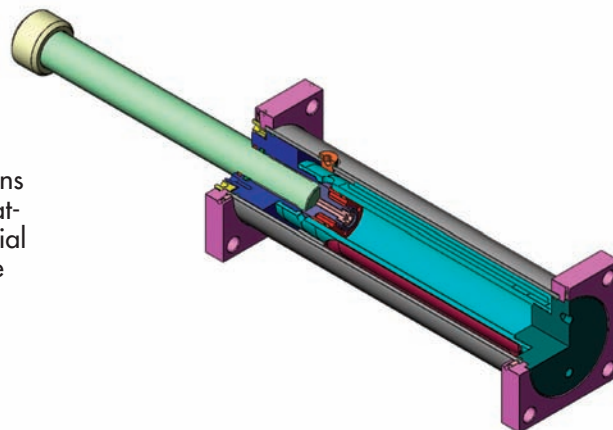

A talented engineering staff works to design and maintain the most efficient energy absorption product lines available today, using the latest engineering tools:

- **Solid Modeling**
- **3-D CAD Drawings**
- **3-D Soluble Support Technology**
- **Finite Element Analysis**
- **Complete Product Verification Testing Facility**

Custom designs are not an exception at Enidine, they are an integral part of our business. Should your requirements fit outside of our standard product range, Enidine engineers can assist in developing special finishes, components, hybrid technologies and new designs to ensure a "best-fit" product solution customized to your exact specifications.

New product designs get to market fast because they can be fully developed in virtual environments before a prototype is ever built. This saves time and lets us optimize the best solution using real performance criteria.

Global Service and Support

Enidine offers its customers a global network of customer service staff technical sales personnel that are available to assist you with all of your application needs.

- Operating with lean manufacturing and cellular production, Enidine produces higher quality custom and standard products with greater efficiency and within shorter lead times.
- An authorized Global Distribution Network is trained regularly by ENIDINE staff on new products and services ensuring they are better able to serve you.
- Global operations in United States, Germany, China and Japan.
- A comprehensive, website full of application information, technical data, sizing examples and information to assist in selecting the product that's right for you.

Our website also features a searchable worldwide distributor lookup to help facilitate fast, localized service. Contact us today for assistance with all of your application needs.



Our global customer service and technical sales departments are available to assist you find the solution that's right for your application needs. Call us at +49 6063 9314 0 or e-mail us at info@enidine.eu and let us get started today.

As companies strive to increase productivity by operating machinery at higher speeds, often the results are increased noise, damage to machinery/products, and excessive vibration. At the same time, safety and machine reliability are decreased. A variety of products are commonly used to solve these problems. However, they vary greatly in effectiveness and operation. Typical products used include rubber bumpers, springs, cylinder cushions and shock absorbers. The following illustrations compare how the most common products perform:

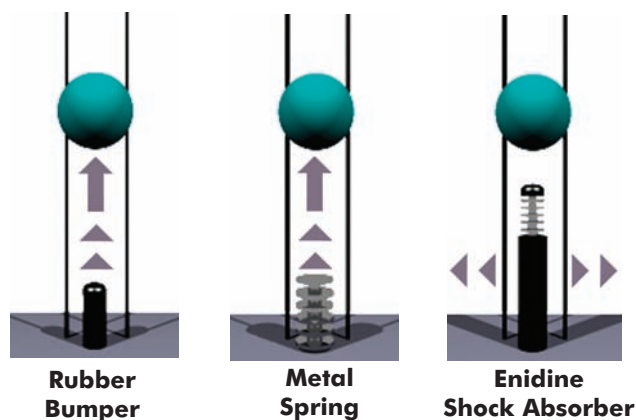

All moving objects possess kinetic energy. The amount of energy is dependent upon weight and velocity. A mechanical device that produces forces diametrically opposed to the direction of motion must be used to bring a moving object to rest.

Rubber bumpers and springs, although very inexpensive, have an undesirable recoil effect. Most of the energy absorbed by these at impact is actually stored. This stored energy is returned to the load, producing rebound and the potential for damage to the load or machinery. Rubber bumpers and springs initially provide low resisting force which increases with the stroke.

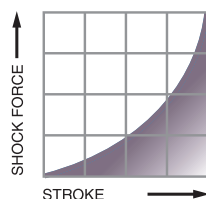

Cylinder cushions are limited in their range of operation. Most often they are not capable of absorbing energy generated by the system. By design, cushions have a relatively short stroke and operate at low pressures resulting in very low energy absorption. The remaining energy is transferred to the system, causing shock loading and vibration.

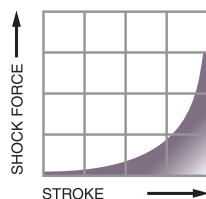

Shock absorbers provide controlled, predictable deceleration. These products work by converting kinetic energy to thermal energy. More specifically, motion applied to the piston of a hydraulic shock absorber pressurizes the fluid and forces it to flow through restricting orifices, causing the fluid to heat rapidly. The thermal energy is then transferred to the cylinder body and harmlessly dissipated to the atmosphere.

Shock Absorber Performance When Weight or Impact Velocity Vary

When conditions change from the original calculated data or actual input, a shock absorber's performance can be greatly affected, causing failure or degradation of performance. Variations in input conditions after a shock absorber has been installed can cause internal damage, or at the very least, can result in unwanted damping performance. Variations in weight or impact velocity can be seen by examining the following energy curves:

Varying Impact Weight: Increasing the impact weight (impact velocity remains unchanged), without reorificing or readjustment will result in increased damping force at the end of the stroke. Figure 1 depicts this undesirable bottoming peak force. This force is then transferred to the mounting structure and impacting load.

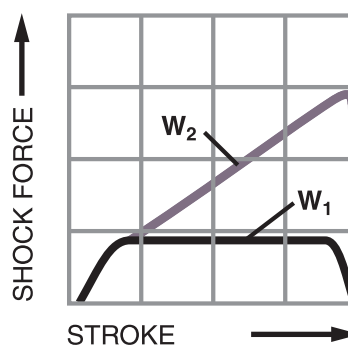

Figure 1

Varying Impact Velocity: Increasing impact velocity (weight remains the same) results in a radical change in the resultant shock force. Shock absorbers are velocity conscious products; therefore, the critical relationship to impact velocity must be carefully monitored. Figure 2 depicts the substantial change in shock force that occurs when the velocity is increased. Variations from original design data or errors in original data may cause damage to mounting structures and systems, or result in shock absorber failure if the shock force limits are exceeded.

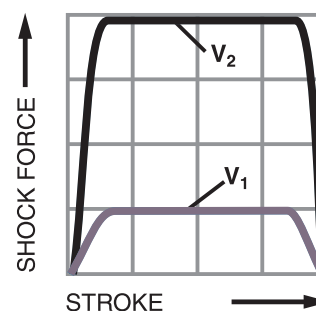

Figure 2

Shock Absorber Sizing Examples

Typical Shock Absorber and Stacker Crane Application

Overview

Application 1	Value
Buffer Distance H	m
Distance X ₁	m
Distance Y ₁	m
Distance X ₂	m
Distance Y ₂	m
Total Weight	t
W _{max d}	t
W _{min d}	t
W _{max u}	t
W _{min u}	t

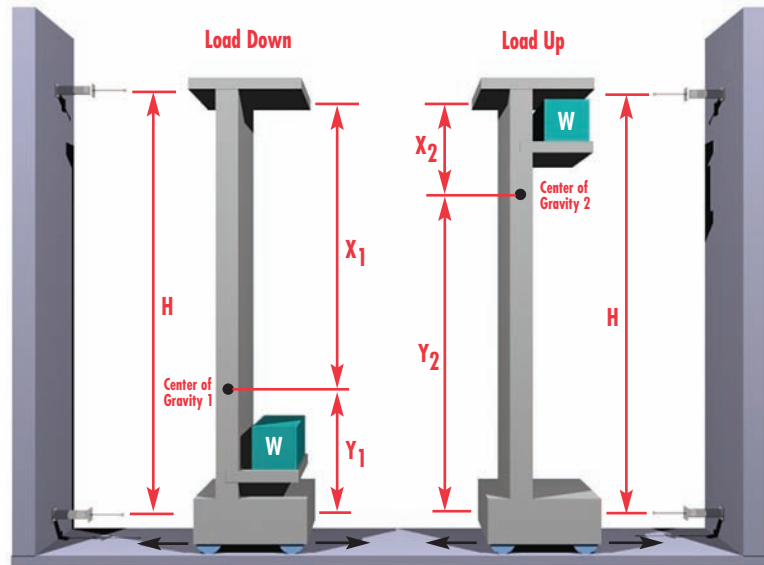

Calculation Example Stacker Cranes

Please note that this example shows how to calculate the maximum impact weight on the upper and lower shock absorbers for a stacker crane.

Distance Between Buffers: Distance to C of G1 - Upper: Distance to C of G1 - Lower: Distance to C of G2 - Upper: Distance to C of G1 - Lower: Total Weight:	H = 20 m X₁ = 15 m Y₁ = 5 m X₂ = 7 m Y₂ = 13 m W = 20 t	Given Values
$W_{\max d} = \frac{X_1}{H} \cdot W$ $W_{\max d} = \frac{15 \text{ m}}{20 \text{ m}} \cdot 20 \text{ t}$ $W_{\max d} = 15 \text{ t}$	$W_{\max d} = \frac{X_2}{H} \cdot W$ $W_{\max d} = \frac{7 \text{ m}}{20 \text{ m}} \cdot 20 \text{ t}$ $W_{\max d} = 7 \text{ t}$	Calculation for Lower Shock Absorbers
$W_{\max d} = \frac{Y_1}{H} \cdot W$ $W_{\max d} = \frac{5 \text{ m}}{20 \text{ m}} \cdot 20 \text{ t}$ $W_{\max d} = 5 \text{ t}$	$W_{\max d} = \frac{Y_2}{H} \cdot W$ $W_{\max d} = \frac{13 \text{ m}}{20 \text{ m}} \cdot 20 \text{ t}$ $W_{\max d} = 13 \text{ t}$	Calculation for Upper Shock Absorbers
Using the value for W_{max} obtained above, the kinetic energy can be calculated, and a shock absorber selected.		Shock Absorber Selection

Shock Absorber Sizing Examples

Typical Shock Absorber and Crane Applications

Calculations assume worst case scenario of 90% trolley weight over one rail.

Crane A		Per Buffer
Propelling Force Crane	kN	
Propelling Force Trolley	kN	
Weight of Crane (W_a)	t	
Weight of Trolley (W_{tA})	t	
Crane Velocity (V_a)	m/s	
Trolley Velocity (V_{tA})	m/s	

Crane B		Per Buffer
Propelling Force Crane	kN	
Propelling Force Trolley	kN	
Weight of Crane (W_a)	t	
Weight of Trolley (W_{tA})	t	
Crane Velocity (V_a)	m/s	
Trolley Velocity (V_{tA})	m/s	

Crane C		Per Buffer
Propelling Force Crane	kN	
Propelling Force Trolley	kN	
Weight of Crane (W_a)	t	
Weight of Trolley (W_{tA})	t	
Crane Velocity (V_a)	m/s	
Trolley Velocity (V_{tA})	m/s	

Please note:

Unless instructed otherwise, Enidine will always calculate with:

- 100% velocity v , and
- 100% propelling force F_D

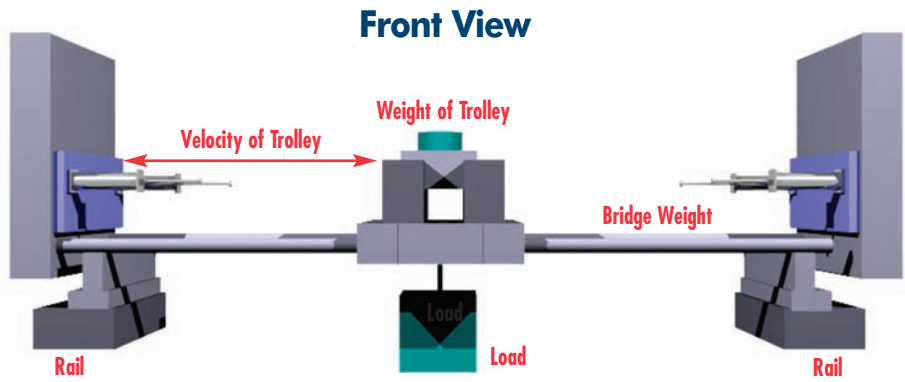

Plan Views

Application 1

Crane A against Solid Stop

Velocity:

$$V_r = V_a$$

Impact weight per buffer:

$$W_d = \frac{W_a + (1.8) W_{tA}}{\text{Total Number of Shocks}}$$

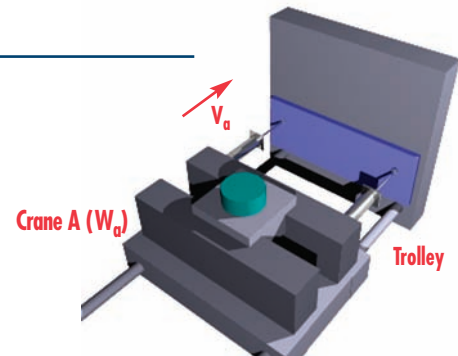

Application 2

Crane A against Crane B

Velocity:

$$V_r = V_a + V_b$$

Impact weight per buffer:

$$W_1 = W_a + (1.8) W_{tA}$$

$$W_2 = W_b + (1.8) W_{tB}$$

$$W_d = \frac{W_1 W_2}{(W_1 + W_2)(\text{Total Number of Shocks})}$$

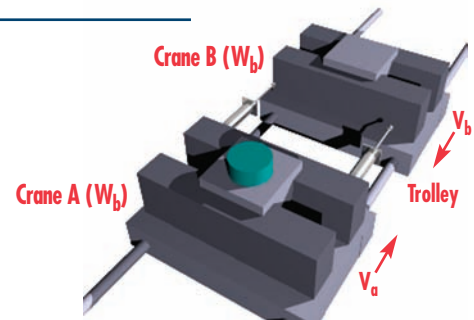

Application 3

Crane B against Crane C

Velocity:

$$V_r = \frac{V_b + V_c}{2}$$

Impact weight per buffer:

$$W_1 = W_b + (1.8) W_{tB}$$

$$W_2 = W_c + (1.8) W_{tC}$$

$$W_d = \frac{2 W_1 W_2}{(W_1 + W_2)(\text{Number of Shocks Per Rail})}$$

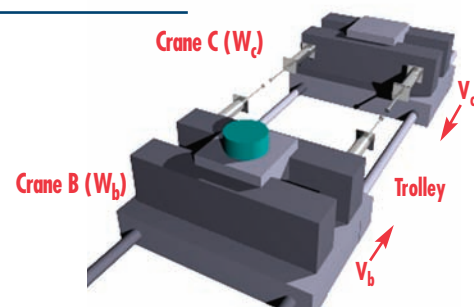

Application 4

Crane C against Solid Stop with Buffer

Velocity:

$$V_r = \frac{V_c}{2}$$

Impact weight per buffer:

$$W_1 = W_c + 1.8 (W_{tC})$$

$$W_d = \frac{2 W_1}{\text{Number of Shocks Per Rail}}$$

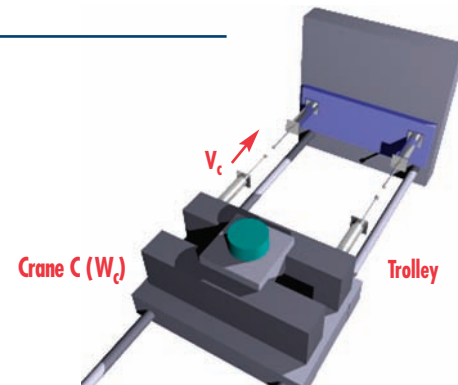

Please note that this example is not based on any particular standard. The slung load can swing freely, and is therefore not taken into account in the calculation.

<p>Total Weight of Bridge: 380 t</p> <p>Weight of Trolley: 45 t</p> <p>Crane Velocity: 1,5 m/s</p> <p>Required Stroke: 600 mm</p> <p>Trolley Velocity: 4,0 m/s</p> <p>Required Stroke: 1 000 m</p>	<p>Calculation Example for Harbor Cranes as Application 1</p> <p>Given Values</p>
$W_d = \frac{W_a + 1.8 W_{+a}}{\text{Total Number of Shocks}}$ $W_d = \frac{380 \text{ t} + (1.8)45 \text{ t}}{2}$ <p>$W_d = 230.5 \text{ t}$</p>	<p>Determination of the Maximum Impact Mass W_d per Buffer</p>
$E_K = \frac{W_d}{2} \cdot V_r^2$ $E_K = \frac{230.5}{2} \cdot (1,5 \text{ m/s})^2$ <p>$E_K = 259 \text{ kNm}$</p> <p>Selecting for required 600mm stroke: HD 5.0 x 24, maximum shock force ca. 460 kN = $F_s = \frac{E_K}{s \cdot \eta}$</p>	<p>$V_r = V_A$ (Application 1)</p> <p>$E_K =$ Kinetic Energy</p> <p>$\eta =$ Efficiency</p> <p>Determine Size of Shock Absorber for Crane</p>
<p>$M_D =$ Trolley Mass per Shock Absorber</p> $M_D = \frac{45 \text{ t}}{2}$ <p>$M_D = 22,5 \text{ t}$</p> $E_K = \frac{M_D}{2} \cdot V_r^2$ $E_K = \frac{22,5 \text{ t}}{2} \cdot (4 \text{ m/s})^2$ <p>$E_K = 180 \text{ kNm}$</p> <p>Selecting for required 1 000 mm stroke: HDN 4.0 x 40, maximum shock force ca. 212 kN = $F_s = \frac{E_K}{s \cdot \eta}$</p>	<p>$V_r = V_A$ Application 1</p> <p>Determine Size of Shock Absorber for Trolley</p>

Heavy Duty Shock Absorbers

HDN, HDA Series

Overview

Enidine Heavy Duty Series large-bore hydraulic shock absorbers protect equipment from large impacts in applications such as automated storage and retrieval systems, as well as overhead bridge and trolley cranes. They are available in a wide variety of stroke lengths and damping characteristics to increase equipment life and meet stringent deceleration requirements.

HDN Series

Custom-orificed design accommodates specified damping requirements. Computer generated output performance simulation is used to optimize the orifice configuration. Available in standard bore dimensions of up to 100mm and strokes over 1524mm.

HDA Series

Adjustable units enable the user to modify shock absorber resistance to accommodate load velocity variations, with strokes up to 305mm. Standard adjustable configurations available.



HDN Series

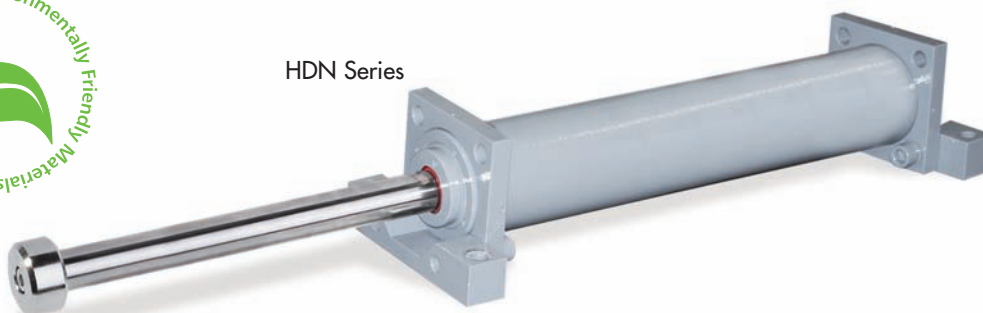

Features and Benefits HDN, HDA

- Designed with Environmentally friendly materials and fluids
- Compact design smoothly and safely decelerates large energy capacity loads up to 330 000 Nm
- Internal charged air/oil accumulator replaces mechanical return springs, providing shorter overall length and reduced weight.
Optional Bladder Accumulator (BA) for higher cycle rates, also available.
- Engineered to meet OSHA, AISE, CMAA and other safety specifications such as DIN and FEM.
- Wide variety of optional configurations including bellows, clevis mounts and safety cables.
- Painted external components provide excellent corrosion protection.
- Epoxy painting and special rod materials are available for use in highly corrosive environments.
- All sizes are fully field repairable.
- Piston rod extension sensor systems available for re-use safety requirements.
- Incorporating optional fluids and seal packages can expand standard operating temperature range from -10°C to 60°C to -35°C to 100°C

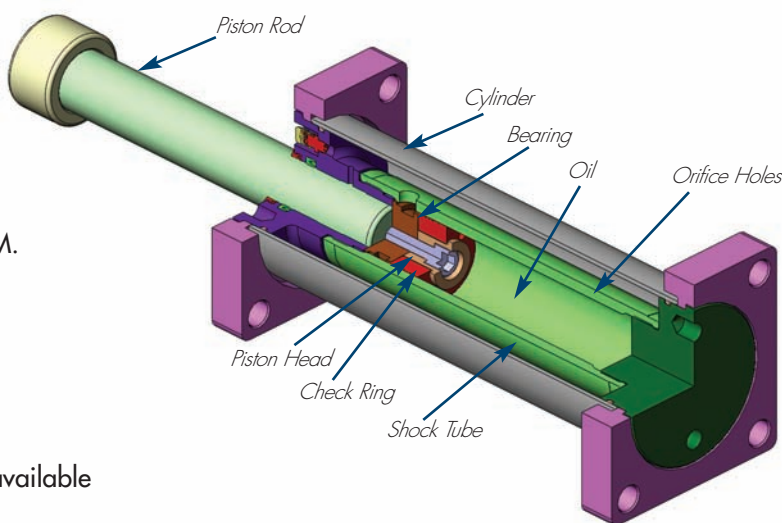

Heavy Duty Series Shock Absorber

HDN 2.0 Series

Technical Data

HDN 2.0 x 6 → HDN 2.0 x 56 Series

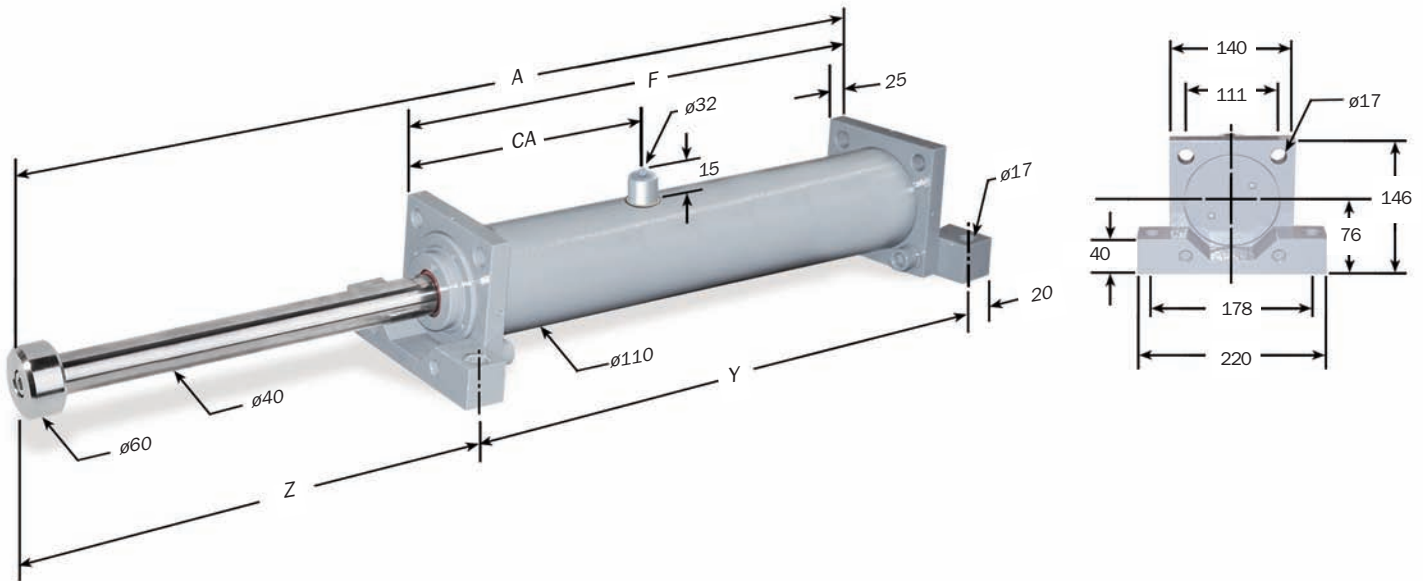

* Denotes Shock Absorber Bladder Accumulator Option.

Note: For TF, FF and FR mounting, delete front foot and dimensions.

Dimensions are in millimeters.

Catalog No./Model	(S) Stroke mm	(E _T) Max. Nm/cycle	(E _C) Max. Nm/hr	(F _P) Max. Shock Force N	Nominal Return Force BA* N	Nominal Return Force w/o BA* N	A mm	F mm	Y mm	Z mm	CA BA* mm	CA w/o BA* mm	Model Weight Kg
HDN 2.0 x 6	152	14 400	862 100	111 200	535	870	553	339	379	194	176	46	23
HDN 2.0 x 8	203	19 200	913 700	111 200	535	1 040	655	390	430	245	176	46	25
HDN 2.0 x 10	250	24 000	1 033 200	111 200	535	1 340	757	441	481	296	176	46	23
HDN 2.0 x 12	300	28 600	1 152 700	111 200	535	2 290	859	492	532	347	176	46	25
HDN 2.0 x 14	350	32 300	1 272 100	111 200	535	2 290	960	543	583	397	176	46	27
HDN 2.0 x 16	400	36 000	1 391 600	111 200	535	2 290	1 062	594	634	448	176	46	29
HDN 2.0 x 18	450	39 700	1 511 100	111 200	535	2 290	1 164	645	685	499	176	46	31
HDN 2.0 x 20	500	43 300	1 628 300	111 200	535	2 290	1 265	695	735	550	176	46	33
HDN 2.0 x 24	600	50 700	1 867 200	111 200	535	2 290	1 469	797	837	652	176	46	36
HDN 2.0 x 28	700	58 200	2 106 200	111 200	535	2 290	1 672	899	939	753	176	46	42
HDN 2.0 x 32	800	70 700	2 527 900	111 200	535	2 290	1 953	1 079	1 119	854	256	46	49
HDN 2.0 x 36	900	77 900	2 762 200	100 000	535	2 290	2 151	1 179	1 219	952	256	46	53
HDN 2.0 x 40	1 000	84 400	2 996 500	84 500	535	2 290	2 351	1 279	1 319	1 052	256	46	56
HDN 2.0 x 48	1 200	95 400	3 465 000	60 000	535	2 290	2 751	1 479	1 519	1 252	256	46	64
HDN 2.0 x 56	1 400	104 200	3 957 000	35 100	535	2 290	3 171	1 689	1 729	1 462	256/975	46	73

Notes: 1. HDN shock absorbers will function satisfactorily at 5% of their maximum rated energy per cycle. If less than these values, a smaller model should be specified.

2. It is recommended that the customer consult Enidine for safety-related overhead crane applications.

3. The energy data listed is for ideal linear impacts only. If side load conditions exist in the application, contact Enidine for sizing assistance.

4. Rear flange mounting of 300 mm strokes and longer not recommended. Front and rear flange or foot mount configurations are recommended.

5. Maximum cycle rate is 60 cycles/hr. for HDN with BA option and 30 cycles/hr. without BA option.

6. For impact velocities over 4.5 m/s, consult factory.

7. ** HDN 2.0 x 56 has two charge ports.

Heavy Duty Series Shock Absorber

HDN 3.0 Series

Technical Data

HDN 3.0 x 2 → HDN 3.0 x 60 Series

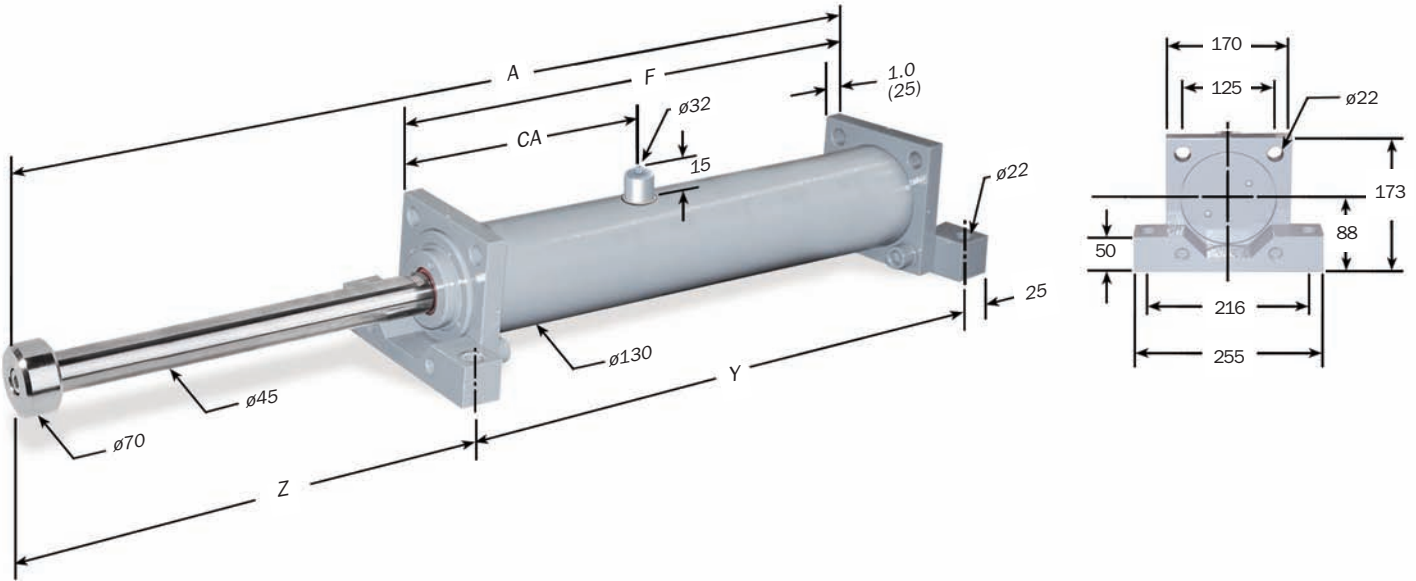

Dimensions are in millimeters.

* Denotes Shock Absorber Bladder Accumulator Option.
Note: For TF, FF and FR mounting, delete front foot and dimensions.

Catalog No./Model	(S) Stroke mm	(E _T) Max. Nm/cycle	(E _T C) Max. Nm/hr	(F _P) Max. Initial Shock Force N	Nominal Return Force BA* N	Nominal Return Force w/o BA* N	A mm	F mm	Y mm	Z mm	CA BA* mm	CA w/o BA* mm	Model Weight Kg
HDN 3.0 x 2	50	9 600	578 500	222 400	670	1 130	336	203	253	108	128	46	21
HDN 3.0 x 3	75	14 600	659 000	222 400	710	1 810	387	229	279	133	128	46	22
HDN 3.0 x 5	125	24 200	805 700	222 400	735	2 895	489	280	330	184	128	46	25
HDN 3.0 x 8	200	35 700	1 021 500	222 400	755	2 895	640	355	405	260	128	46	29
HDN 3.0 x 10	250	43 200	1 168 300	222 400	780	2 895	742	406	456	311	128	46	32
HDN 3.0 x 12	300	50 700	1 315 000	222 400	780	2 895	844	457	507	362	128	46	35
HDN 3.0 x 14	350	62 900	1 605 700	222 400	800	2 895	995	558	608	412	178	46	43
HDN 3.0 x 16	400	70 400	1 752 400	222 400	800	2 895	1 097	609	659	463	178	46	45
HDN 3.0 x 18	450	77 900	1 899 200	222 400	800	2 895	1 199	660	710	514	178	46	48
HDN 3.0 x 20	500	85 400	2 046 000	222 400	800	2 895	1 301	711	761	565	178	46	51
HDN 3.0 x 24	600	100 300	2 336 600	222 400	800	2 895	1 504	812	862	667	178	46	57
HDN 3.0 x 28	700	115 300	2 630 100	222 400	800	2 895	1 707	914	964	768	178	46	62
HDN 3.0 x 32	800	130 200	2 920 700	180 200	800	2 895	1 910	1 015	1 065	870	178	46	68
HDN 3.0 x 36	900	147 700	3 349 500	160 100	800	2 895	2 156	1 164	1 214	967	228	46	77
HDN 3.0 x 40	1 000	159 600	3 637 200	140 000	800	2 895	2 356	1 264	1 314	1 067	228	46	85
HDN 3.0 x 48	1 200	179 700	4 212 800	95 600	825	2 895	2 756	1 464	1 514	1 267	228	46	94
HDN 3.0 x 56	1 400	196 700	4 788 300	55 600	825	2 895	3 156	1 664	1 714	1 467	234/947	46	106
HDN 3.0 x 60	1 500	206 800	5 116 300	53 200	825	2 895	3 384	1 778	1 828	1 581	228/1004	46	106

Notes: 1. HDN shock absorbers will function satisfactorily at 5% of their maximum rated energy per cycle. If less than these values, a smaller model should be specified.

2. It is recommended that the customer consult Enidine for safety-related overhead crane applications.

3. The energy data listed is for ideal linear impacts only. If side load conditions exist in the application, contact Enidine for sizing assistance.

4. Rear flange mounting of 300 mm strokes and longer not recommended. Front and rear flange or foot mount configurations are recommended.

5. Maximum cycle rate is 60 cycles/hr. for HDN with BA option and 30 cycles/hr. without BA option.

6. For impact velocities over 4.5 m/s, consult factory.

7. ** HDN 3.0 x 56 and HDN 3.0 x 60 have 2 charge ports.

Heavy Duty Series Shock Absorber

HDN 3.5 Series

Technical Data

HDN 3.5 x 2 → HDN 3.5 x 56 Series

Heavy Duty Series

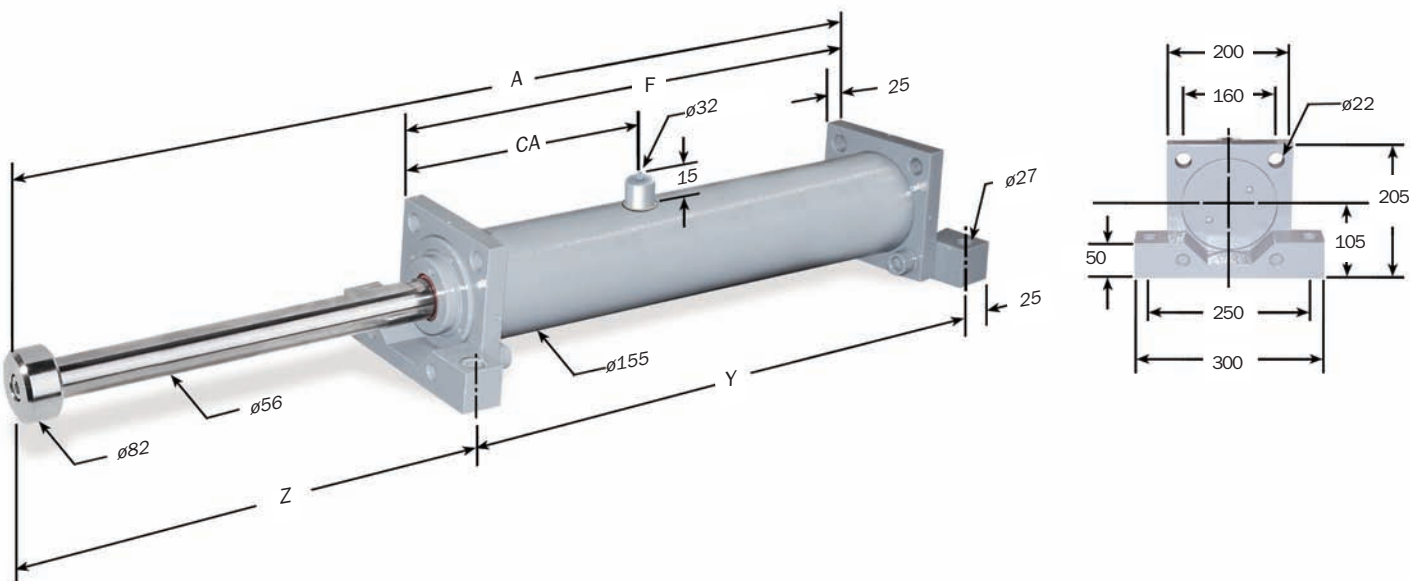

Dimensions are in millimeters.

* Denotes Shock Absorber Bladder Accumulator Option.
Note: For TF, FF and FR mounting, delete front foot and dimensions.

Catalog No./ Model	(S) Stroke mm	(E _F) Max. Nm/cycle	(E _F C) Max. Nm/hr	(F _P) Max. Shock Force N	Nominal Return Force BA* N	Nominal Return Force w/o BA* N	A mm	F mm	Y mm	Z mm	CA BA* mm	CA w/o BA* mm	Model Weight Kg
HDN 3.5 x 2	50	13 000	781 000	300 250	960	2 020	354	244	294	85	134	52	33
HDN 3.5 x 4	100	26 000	993 500	300 250	1 020	2 710	456	295	345	136	134	52	37
HDN 3.5 x 6	150	38 800	1 161 900	300 250	1 160	4 480	556	345	395	186	134	52	41
HDN 3.5 x 8	200	50 900	1 333 600	300 250	1 180	4 480	658	396	446	237	134	52	45
HDN 3.5 x 10	250	60 800	1 505 400	300 250	1 200	4 480	760	447	497	288	134	52	49
HDN 3.5 x 12	300	70 800	1 677 200	300 250	1 200	4 480	862	498	548	339	134	52	53
HDN 3.5 x 16	400	90 500	2 017 300	300 250	1 225	4 480	1 064	599	649	440	134	52	60
HDN 3.5 x 20	500	118 800	2 546 100	300 250	1 225	4 480	1 323	756	806	542	189	52	74
HDN 3.5 x 24	600	138 700	2 889 600	300 250	1 250	4 480	1 527	858	908	644	189	52	81
HDN 3.5 x 28	700	158 500	3 229 700	300 250	1 250	4 480	1 729	959	1 009	745	189	52	89
HDN 3.5 x 32	800	178 400	3 573 200	300 250	1 250	4 480	1 933	1 061	1 111	847	189	52	97
HDN 3.5 x 36	900	198 300	3 916 800	260 200	1 250	4 480	2 137	1 163	1 213	949	189	52	105
HDN 3.5 x 40	1 000	216 800	4 256 900	215 700	1 250	4 480	2 339	1 264	1 314	1 050	189	52	112
HDN 3.5 x 48	1 200	247 200	4 930 500	155 700	1 250	4 480	2 739	1 464	1 514	1 250	189	52	128
HDN 3.5 x 56	1 400	273 300	5 604 000	112 500	2 100	4 480	2 739	1 464	1 514	1 250	189/908	52	128

Notes: 1. HDN shock absorbers will function satisfactorily at 5% of their maximum rated energy per cycle. If less than these values, a smaller model should be specified.

- It is recommended that the customer consult Enidine for safety-related overhead crane applications.
- The energy data listed is for ideal linear impacts only. If side load conditions exist in the application, contact Enidine for sizing assistance.
- Rear flange mounting of 300 mm strokes and longer not recommended. Front and rear flange or foot mount configurations are recommended.
- Maximum cycle rate is 60 cycles/hr. for HDN with BA option and 30 cycles/hr. without BA option.
- For impact velocities over 4.5 m/s, consult factory.
- ** HDN 3.5 x 56 has two charge ports.

Heavy Duty Series Shock Absorber

HDN 4.0 Series

HDN 4.0 x 2 → HDN 4.0 x 48 Series

Technical Data

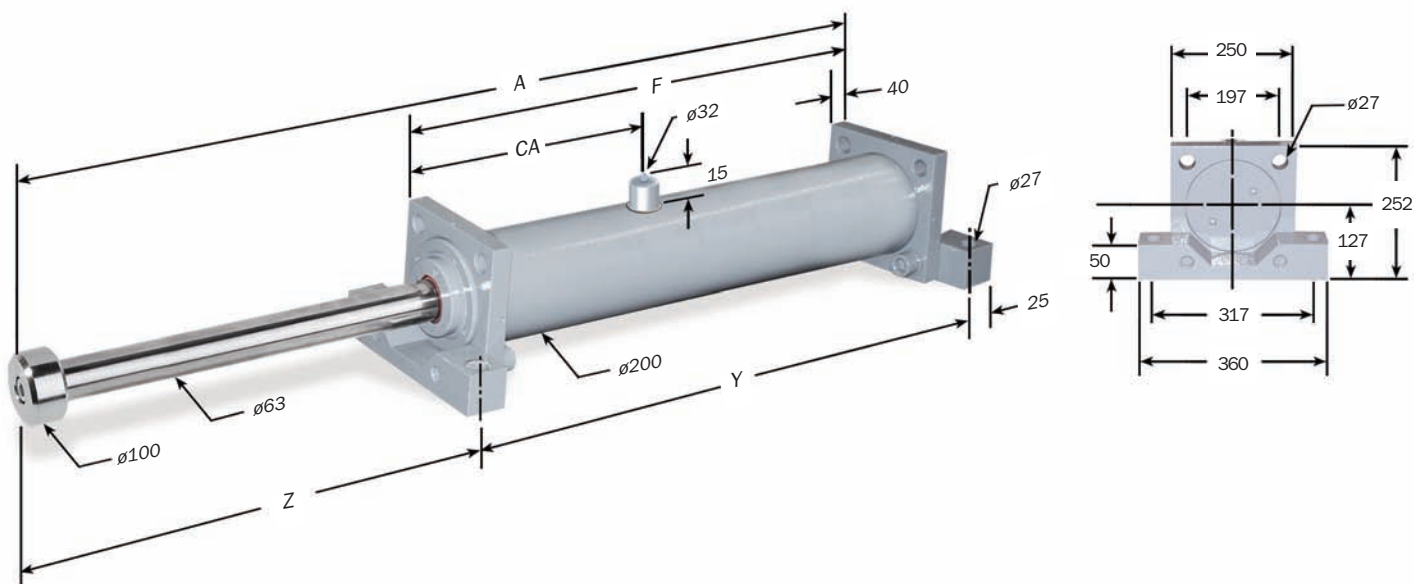

Dimensions are in millimeters.

* Denotes Shock Absorber Bladder Accumulator Option.

Note: For TF, FF and FR mounting, delete front foot and dimensions.

Catalog No./ Model	(S) Stroke mm	(E _T) Max. Nm/cycle	(F _P) (E _T C) Max. Nm/hr	Nominal Max. Shock Force N	Nominal Return Force BA* N	Return Force w/o BA* N	A mm	F mm	Y mm	Z mm	CA BA* mm	CA w/o BA* mm	Model Weight Kg
HDN 4.0 x 2	50	15 700	943 700	355 900	1 100	1 900	430	294	344	111	206	64	64
HDN 4.0 x 4	100	31 200	1 534 300	355 900	1 200	2 160	532	345	395	162	206	64	70
HDN 4.0 x 6	150	46 279	1 756 700	355 900	1 200	3 050	632	395	445	212	206	64	76
HDN 4.0 x 8	200	62 000	1 987 900	355 900	1 200	4 370	735	447	497	263	206	64	82
HDN 4.0 x 10	250	77,100	2 210 300	355 900	1 200	5 465	836	497	547	314	206	64	87
HDN 4.0 x 12	300	92 600	1 855 100	355 900	1 225	4 440	1 032	642	692	365	300	64	108
HDN 4.0 x 16	400	123,100	3 304 300	355 900	1 225	5 650	1 234	743	793	466	300	64	120
HDN 4.0 x 20	500	154 000	3 757 900	355 900	1 245	5 145	1 438	845	895	568	300	64	131
HDN 4.0 x 24	600	184 800	4 211 500	355 900	1 245	5 675	1 642	947	997	670	300	64	144
HDN 4.0 x 28	700	215 100	4 660 700	355 900	1 245	5 675	1 844	1 048	1 098	771	300	64	157
HDN 4.0 x 32	800	240 500	5 114 300	355 900	1 245	5 675	2 048	1 150	1 200	873	300	64	170
HDN 4.0 x 36	900	265 900	5 567 900	355 900	1 245	5 675	2 252	1 252	1 302	975	300	64	183
HDN 4.0 x 40	1 000	289 900	6 017 100	355 900	1 245	5 675	2 454	1 353	1 403	1 076	300	64	195
HDN 4.0 x 48	1 200	329 300	6 919 900	200 000	1 245	5 675	2 854	1 556	1 606	1 273	300	64	220

Notes: 1. HDN shock absorbers will function satisfactorily at 5% of their maximum rated energy per cycle. If less than these values, a smaller model should be specified.

2. It is recommended that the customer consult Enidine for safety-related overhead crane applications.

3. The energy data listed is for ideal linear impacts only. If side load conditions exist in the application, contact Enidine for sizing assistance.

4. Rear flange mounting of 300 mm strokes and longer not recommended. Front and rear flange or foot mount configurations are recommended.

5. Maximum cycle rate is 60 cycles/hr. for HDN with BA option and 30 cycles/hr. without BA option.

6. For impact velocities over 4.5 m/s, consult factory.

Heavy Duty Adjustable Series Shock Absorber

HDA 3.0 Series

Technical Data

HDA 3.0 x 2 → HDA 3.0 x 12 Series

Heavy Duty Series

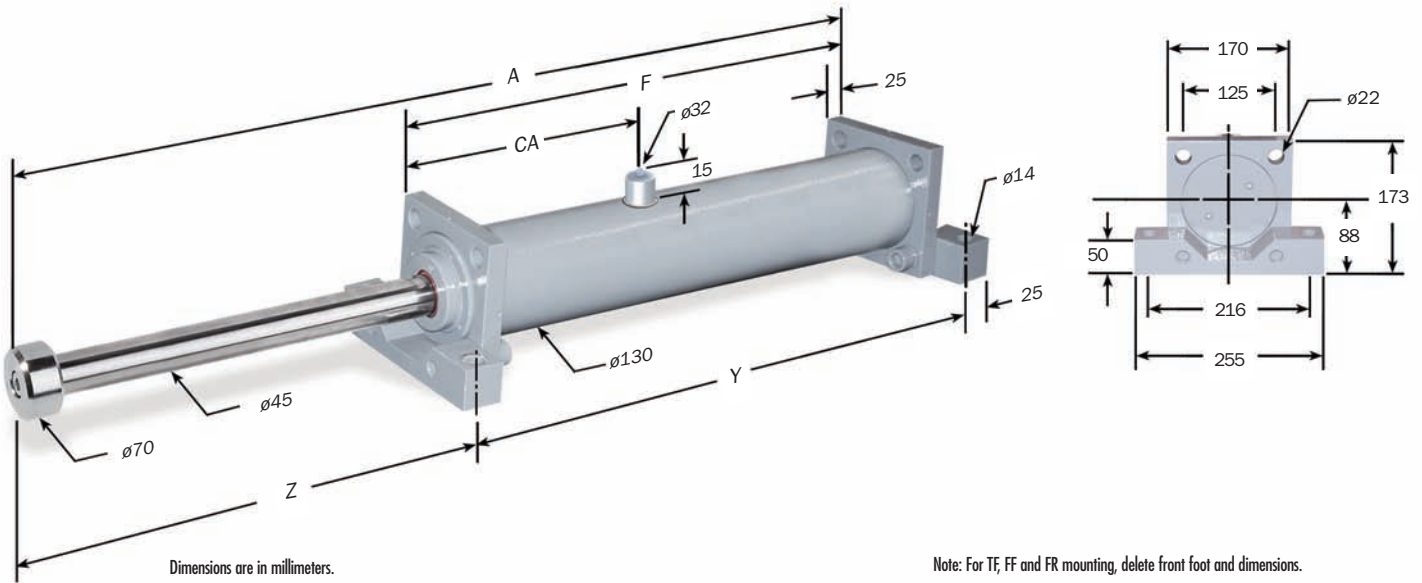

Catalog No./ Model	(S) Stroke mm	(E _T) Max. Nm/cycle	(E _{T-C}) Max. Nm/hr	(F _P) Max. End Shock Force N	Nominal Return Force BA* N	A mm	F mm	Y mm	Z mm	CA* mm	Model Weight Kg
HDA 3.0 x 2	50	4 500	271 200	222 400	660	336	213	263	98	112	21
HDA 3.0 x 3	75	6 800	406 700	222 400	710	387	239	289	123	112	22
HDA 3.0 x 5	125	11 300	677 900	222 400	730	489	290	340	174	112	25
HDA 3.0 x 8	200	18 100	1 050 300	222 400	765	640	365	415	250	112	29
HDA 3.0 x 10	250	22 600	1 197 100	222 400	775	742	416	466	301	112	32
HDA 3.0 x 12	300	27 200	1 343 800	222 400	775	844	467	517	352	112	35

- Notes:
- HDA shock absorbers will function satisfactorily at 5% of their maximum rated energy per cycle. If less than these values, a smaller model should be specified.
 - It is recommended that the customer consult Enidine for safety-related overhead crane applications.
 - The energy data listed is for ideal linear impacts only. If side load conditions exist in the application, contact Enidine for sizing assistance.
 - Rear flange mounting of 300 mm strokes and longer not recommended. Front and rear flange or foot mount configurations are recommended.
 - Maximum cycle rate is 60 cycles/hr.
 - HDA models which have an impact velocity below .8 m/sec., please contact Enidine for assistance.
 - Maximum allowable applied propelling force: 111 200 N

Adjustment Techniques

Useable Adjustment Setting Range

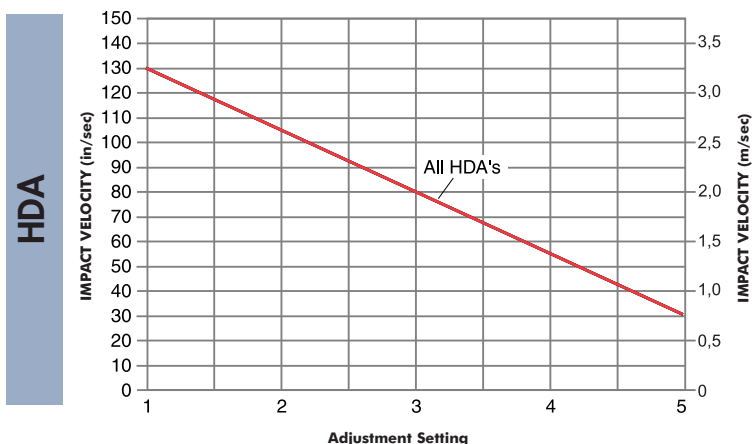

After properly sizing an HDA shock absorber, the useable range of adjustment settings can be determined:

- Locate the intersection point of the application's impact velocity and the HDA model graph line.
- The intersection is the maximum adjustment setting to be used. Adjustments exceeding this setting could overload the shock absorber.
- The useable adjustment setting range is from setting 1 to the MAXIMUM adjustment setting as determined in step 2.

EXAMPLE: HDA Series

- Impact Velocity: 2 m/s
- Intersection Point: Adjustment Setting 3
- Useable Adjustment Setting Range: 1 to 3

Heavy Duty Adjustable Series Shock Absorber

HDA 4.0 Series

Technical Data

HDA 4.0 x 2 → HDA 4.0 x 10 Series

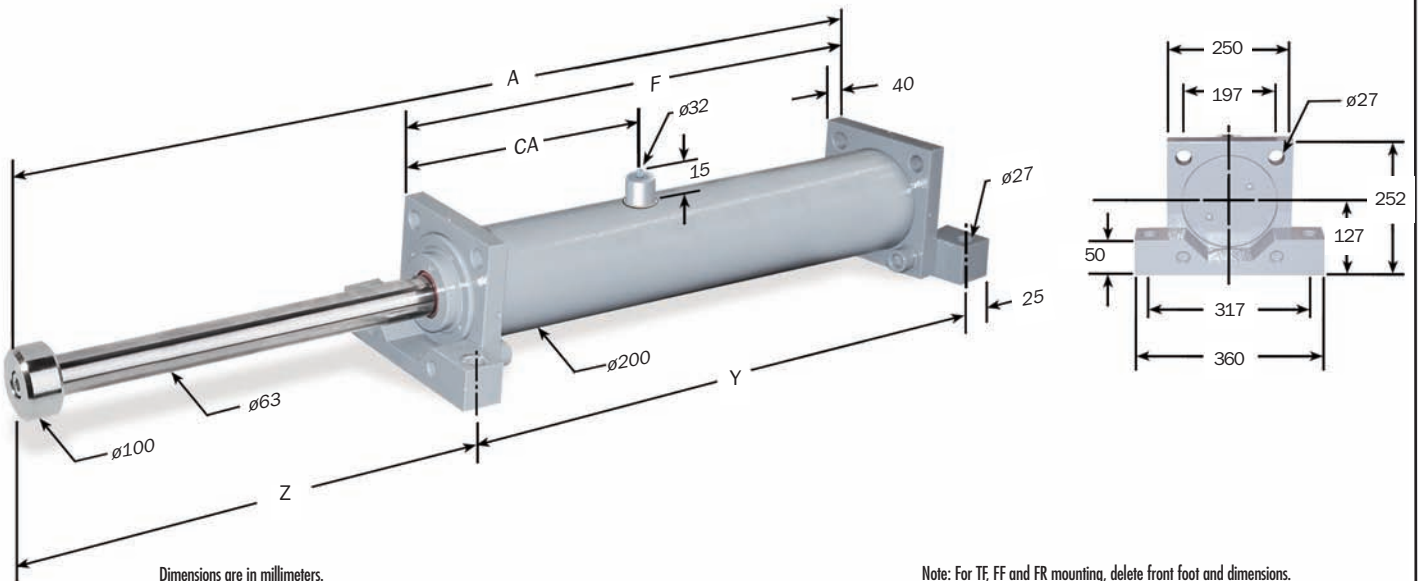

Catalog No./ Model	(S) Stroke mm	(E _T) Max. Nm/cycle	(E _T -C) Max. Nm/hr	(F _P) Max. Shock Force N	Nominal Return Force BA* N	A mm	F mm	Y mm	Z mm	CA* mm	Model Weight Kg
HDA 4.0 x 2	50	13 600	813 500	355 900	1 125	430	304	354	101	180	64
HDA 4.0 x 4	100	27 100	1 578 800	355 900	1 125	532	355	405	152	180	70
HDA 4.0 x 6	150	40 700	1 801 100	355 900	1 125	632	405	455	202	180	76
HDA 4.0 x 8	200	54 200	2 032 400	355 900	1 125	735	457	507	253	180	82
HDA 4.0 x 10	250	67 800	2 254 700	355 900	1 125	836	507	557	304	180	87

- Notes: 1. HDA shock absorbers will function satisfactorily at 5% of their maximum rated energy per cycle. If less than these values, a smaller model should be specified.
 2. It is recommended that the customer consult Enidine for safety-related overhead crane applications.
 3. The energy data listed is for ideal linear impacts only. If side load conditions exist in the application, contact Enidine for sizing assistance.
 4. Rear flange mounting of 300 mm strokes and longer not recommended. Front and rear flange or foot mount configurations are recommended.
 5. Maximum cycle rate is 60 cycles/hr.
 6. HDA models which have an impact velocity below .8 m/sec., please contact Enidine for assistance.
 7. Maximum allowable applied propelling force: 177 900 N

Damping Force

Position 1 provides minimum damping force.
 Position 5 provides maximum damping force.

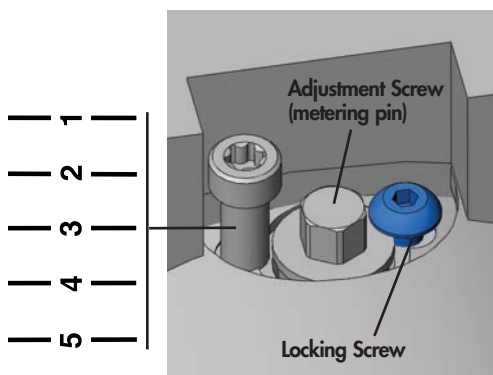

Adjustment Technique

1. Loosen socket head cap screw.
2. Set adjustment screw desired location.
3. Tighten socket head cap screw on shoulder of adjustment screw.

HD Series

Custom-orificed design accommodates specified damping requirements. Computer generated output performance simulation is used to optimize the orifice configuration. Available in standard bore dimensions of up to 125mm and 156mm with strokes over 1525mm.

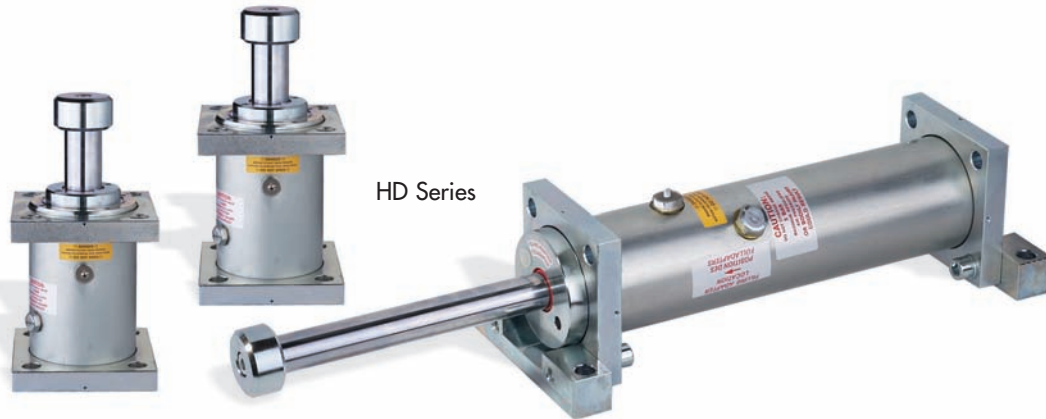

Features and Benefits HD

- Compact design smoothly and safely decelerates large energy capacity loads up to 900 000 Nm
- Engineered to meet OSHA, AISE, CMAA and other safety specifications such as DIN and FEM.
- Internal air charged bladder accumulator replaces mechanical return springs, providing shorter overall length and reduced weight.
- Wide variety of optional configurations including bellows, clevis mounts and safety cables.
- Available in standard adjustable or custom-orificed non-adjustable models.
- Zinc plated external components provide enhanced corrosion protection.
- Epoxy painting and special rod materials are available for use in highly corrosive environments.
- All sizes are fully field repairable.
- Piston rod extension sensor systems available for reuse safety requirements.
- Incorporating optional fluids and seal packages can expand standard operating temperature range from -10°C to 60°C to -35°C to 100°C

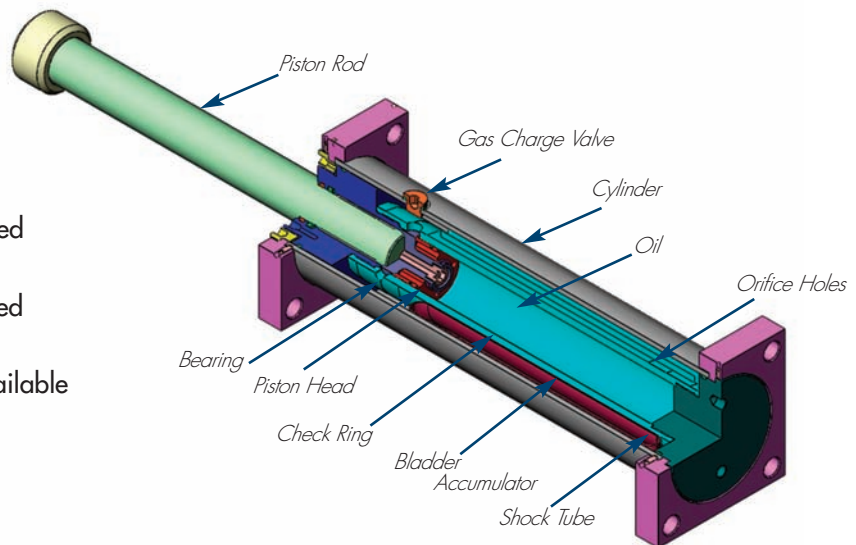

Heavy Duty Series Shock Absorber

HD 5.0 Series

Technical Data

HD 5.0 x 4 → HD 5.0 x 48 Series

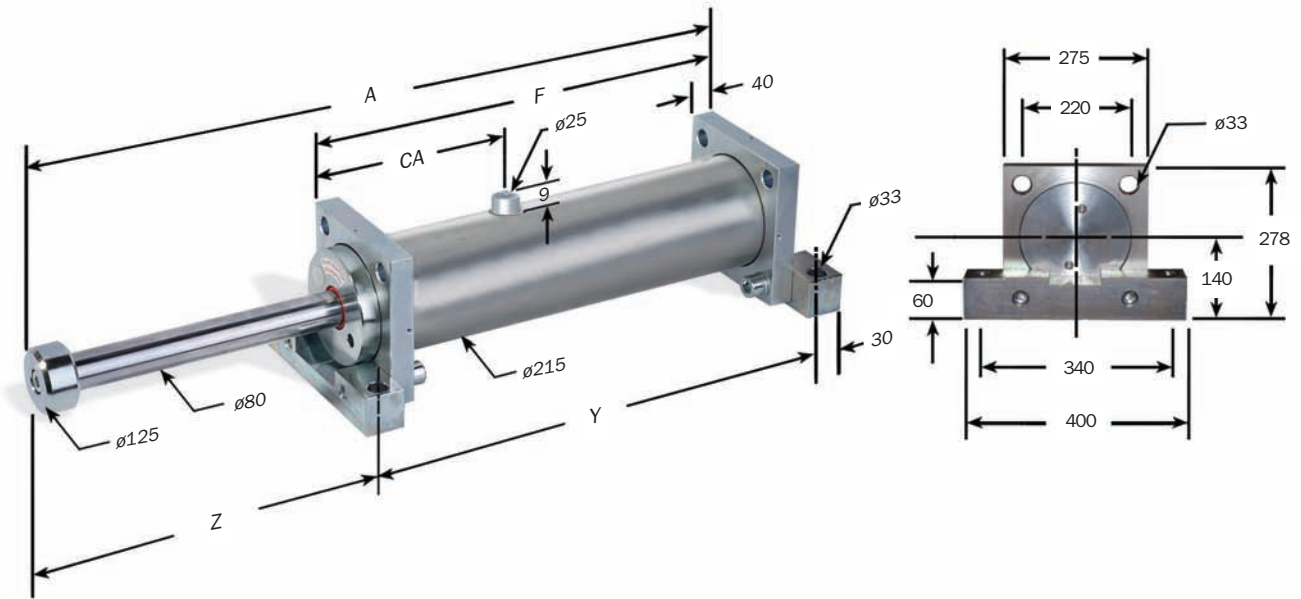

Dimensions are in millimeters.

Note: For TF, FF and FR mounting, delete front foot and dimensions.

Catalog No./ Model	(S) Stroke mm	(E ₁) Max. Nm/cycle	(E ₁ C) Max. Nm/hr	(F _p) Max. Shock Force N	Nominal Return Force BA* N	A mm	F mm	Y mm	Z mm	CA mm	Model Weight Kg
HD 5.0 x 4	100	46 700	1 762 621	550 000	1 760	591	37.5	435	186	230	87
HD 5.0 x 6	150	70 000	2 002 337	550 000	1 760	693	426	486	237	230	94
HD 5.0 x 8	200	93 500	2 242 053	550 000	1 760	795	477	537	288	230	101
HD 5.0 x 10	250	117 000	2 477 070	550 000	1 760	895	527	587	338	230	108
HD 5.0 x 12	300	140 000	2 716 786	550 000	1 760	997	578	638	389	230	114
HD 5.0 x 16	400	187 000	3 196 219	550 000	1 760	1 201	680	740	491	230	128
HD 5.0 x 20	500	234 000	4 145 684	550 000	1 760	1 504	882	942	592	230	158
HD 5.0 x 24	600	280 000	4 625 117	550 000	1 760	1 708	984	1 044	694	230	171
HD 5.0 x 28	700	327 000	5 099 849	550 000	1 760	1 910	1 085	1 145	795	230	185
HD 5.0 x 32	800	374 000	5 579 282	550 000	1 760	2 114	1 187	1 247	897	230	198
HD 5.0 x 40	1 000	467 000	6 533 447	550 000	1 760	2 520	1 390	1 450	1 100	231	225
HD 5.0 x 48	1 200	535 800	7 487 613	410 000	1 760	2 920	1 590	1 650	1 300	230	242

Notes: 1. HD shock absorbers will function satisfactorily at 5% of their maximum rated energy per cycle.

HDA models will function satisfactorily at 10% of their maximum rated energy per cycle. If less than these values, a smaller model should be specified.

- It is recommended that the customer consult Enidine for safety-related overhead crane applications.
- The energy data listed is for ideal linear impacts only. If side load conditions exist in the application, contact Enidine for sizing assistance.
- Rear flange mounting of 300 mm strokes and longer not recommended. Front and rear flange or foot mount configurations are recommended.
- Maximum cycle rate is 60 cycles/hr.
- For impact velocities over 4.5 m/s, consult factory.

Heavy Duty Series Shock Absorber

HD 6.0 Series

Technical Data

HD 6.0 x 4 → HD 6.0 x 48 Series

Heavy Duty Series

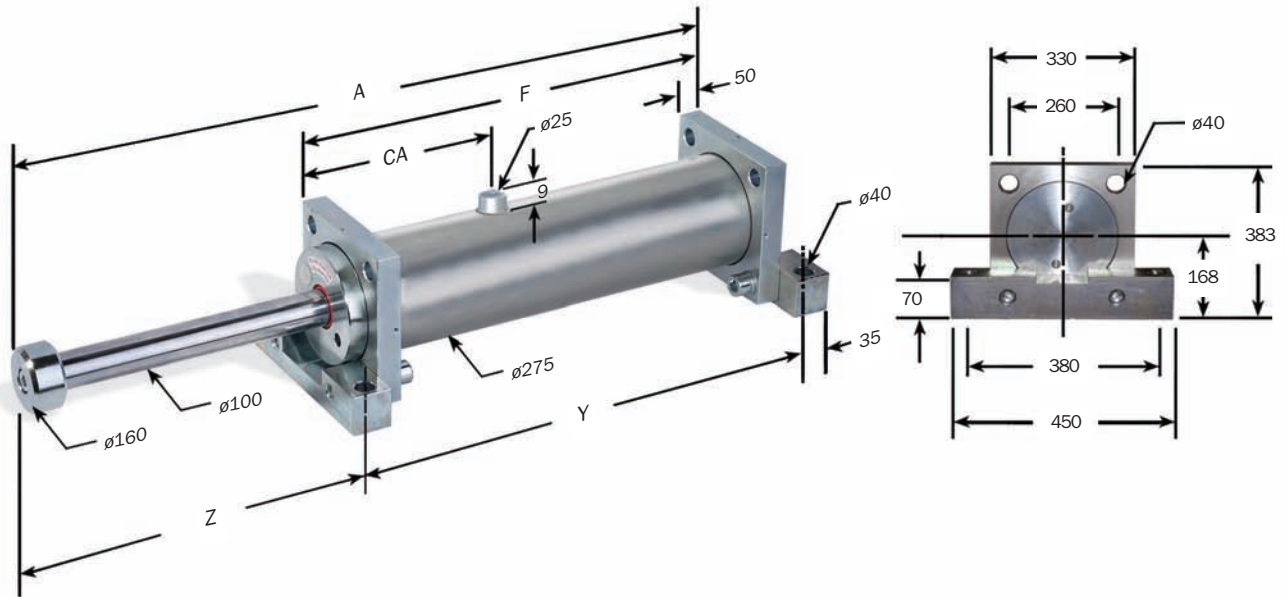

Dimensions are in millimeters.

Note: For TF, FF and FR mounting, delete front foot and dimensions.

Catalog No./ Model	(S) Stroke mm	(E _T) Max. Nm/cycle	(E _T C) Max. Nm/hr	(F _P) Max. Shock Force N	Nominal Return Force BA* N	A mm	F mm	Y mm	Z mm	CA mm	Model Weight Kg
HD(A) 6.0 x 4	100	76 500	2 404 568	900 000	2 750	637	391	461	211	197	164
HD(A) 6.0 x 6	150	114 000	2 704 389	900 000	2 750	737	441	511	261	197	175
HD(A) 6.0 x 8	200	153 000	3 004 211	900 000	2 750	839	492	562	312	197	186
HD(A) 6.0 x 10	250	191 000	3 316 025	900 000	2 750	941	543	613	363	197	196
HD(A) 6.0 x 12	300	224 000	3 621 843	900 000	2 750	1 043	594	664	414	197	207
HD 6.0 x 16	400	306 000	4 233 478	900 000	2 750	1 246	696	766	515	197	228
HD 6.0 x 20	500	382 000	4 845 114	900 000	2 750	1 450	798	868	617	197	250
HD 6.0 x 24	600	459 000	6 086 375	900 000	2 750	1 769	1 015	1 085	719	312	309
HD 6.0 x 30	750	573 000	6 997 832	900 000	2 750	2 073	1 167	1 237	871	312	341
HD 6.0 x 36	900	688 500	7 915 285	900 000	2 750	2 379	1 320	1 390	1 024	312	373
HD 6.0 X 42	1 050	803 000	8 826 743	900 000	2 750	2 683	1 472	1 542	1 176	312	405
HD 6.0 x 48	1 200	898 200	9 744 196	750 000	2 750	2 989	1 625	1 695	1 329	312	438

Notes: 1. HD shock absorbers will function satisfactorily at 5% of their maximum rated energy per cycle.

HDA models will function satisfactorily at 10% of their maximum rated energy per cycle. If less than these values, a smaller model should be specified.

2. It is recommended that the customer consult Enidine for safety-related overhead crane applications.

3. The energy data listed is for ideal linear impacts only. If side load conditions exist in the application, contact Enidine for sizing assistance.

4. Rear flange mounting of 300 mm strokes and longer not recommended. Front and rear flange or foot mount configurations are recommended.

5. HDA models which have an impact velocity below .8 m/sec., please contact Enidine for sizing assistance.

6. Maximum cycle rate is 60 cycles/hr.

7. For impact velocities over 4.5 m/s, consult factory.

Heavy Duty Series Shock Absorber

Mounting and Accessories for HDN, HD, HDA Series

Mounting and Accessories

Typical mounting methods are shown below. Special mounting requirements can be accommodated upon request.



TM: Rear Flange Front Foot Mount



FM: Front and Rear Foot Mount
Also shown is optional safety cable, typically used in overhead applications.



TF: Front and Rear Flanges



FF: Front Flange



CM: Clevis Mount



FR: Rear Flange

Note: Rear flange mounting not recommended for stroke lengths above 12 inches. (300 mm)

HD(A) 3.0 x 2 → HD(A) 4.0 x 10 Series

Clevis Mounts (CM)

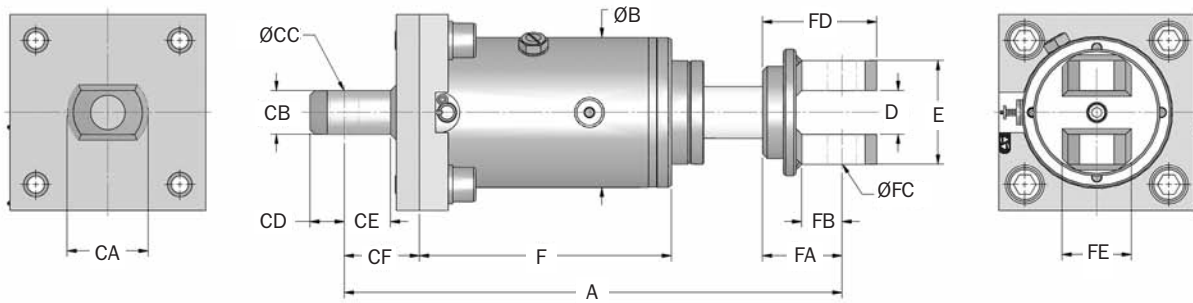

Dimensions are in inches (millimeters).

Note: Piston clevis dimensions are typical both ends on HD(A) 4.0 models.

Catalog No./Model	A mm	B mm	D mm	E mm	HD/HDN F mm	HDA F mm	Cylinder Clevis Dimensions						Piston Clevis Dimensions				
							CA mm	CB mm	CC mm	CD mm	CE mm	CF mm	FA mm	FB mm	FC mm	FD mm	FE mm
HD(A) 3.0 x 2	432	130	38	90	202	235	60	38	25	30	37	65	69	32	25	99	50
HD(A) 3.0 x 3	483	130	38	90	229	261	60	38	25	30	37	65	69	32	25	99	50
HD(A) 3.0 x 5	585	130	38	90	280	312	60	38	25	30	37	65	69	32	25	99	50
HD(A) 3.0 x 8	736	130	38	90	350	387	60	38	25	30	37	65	69	32	25	99	50
HD(A) 3.0 x 10	838	130	38	90	406	438	60	38	25	30	37	65	69	32	25	99	50
HD(A) 3.0 x 12	940	130	38	90	457	489	60	38	25	30	37	65	69	32	25	99	50
HD(A) 4.0 x 2	570	200	65	140	294	304	–	–	–	–	–	90	100	60	50	150	100
HD(A) 4.0 x 4	672	200	65	140	345	355	–	–	–	–	–	90	100	60	50	150	100
HD(A) 4.0 x 6	772	200	65	140	395	405	–	–	–	–	–	90	100	60	50	150	100
HD(A) 4.0 x 8	875	200	65	140	477	457	–	–	–	–	–	90	100	60	50	150	100
HD(A) 4.0 x 10	976	200	65	140	497	507	–	–	–	–	–	90	100	60	50	150	100

Optional Piston Rod Return Sensor

- Magnetic proximity sensor indicates complete piston rod return with 3 m long cable.
- If complete piston rod does not return the circuit remains open. This can be used to trigger a system shut-off.
- Contact Enidine for other available sensor types.
- Sensor port in line with charge port on models HDN 1.5, 2.0 and 4.0. Location offset 90° for models HDN 3.0 and 3.5.

Sensor Specifications

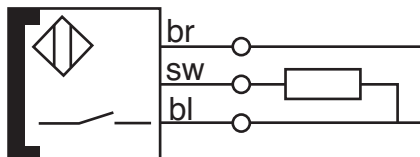

- Voltage 10 - 30V
- Load Current \leq 200 mA
- Leakage Current \leq 80 mA
- Load Capacitance \leq 1.0 mF
- Ambient Temperature: -26° to 71°C

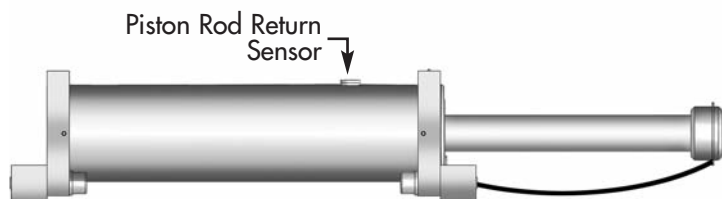

Urethane Cap

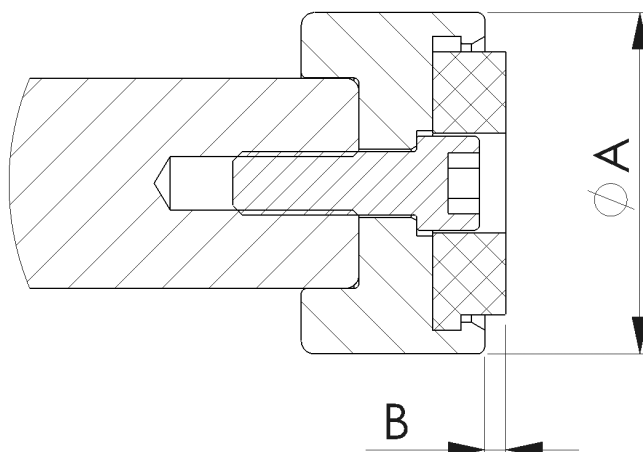

Model	Dia. A (mm)	B (mm)
HDN 1.5	60	4
HDN 2.0	65	4
HDN 3.0	70	4

HEAVY DUTY SHOCK ABSORBERS

Applications:

- Control of bridge cranes
- Trolley platforms
- Large container transfer
- Automated aisle stacker cranes
- Cab operated bridge cranes
- Ship to shore container cranes
- Overhead bridge cranes
- Gantry cranes
- Ship to shore container cranes
- Transportation end stops

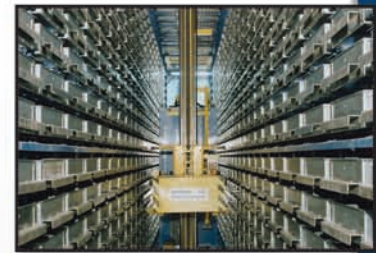

!! DANGER !!
WARNING: RISK OF INJURY UNDER PRESSURE
ACHTUNG: FOLGESCHADEN BEI DRUCK UNTER BRUCKE
!! DO NOT OPEN !!

CAUTION:
DO NOT EXCEED ABOVE
3 BAR
DO NOT INSULATE
OR PRESSURE
INCREASED DANGER
FIRE/EXPLOSION RESULT

Enidine Incorporated

7 Centre Drive
Orchard Park, New York 14127
USA

Phone: 716-662-1900

Fax: 716-662-1909

Email: industrialsales@enidine.com

www.enidine.com

ITT Control Technologies EMEA

Werkstrasse 5
D-64732, Bad Koenig
Germany

Phone: +49 6063 9314 0

Fax: +49 6063 9314 44

www.enidine.eu